

Solutions For
Wireless Communications
Personal Digital Assistant (PDA)

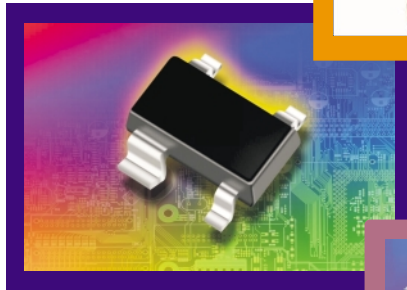

PROTEK[®] DEVICES

ESD PROTECTION & EMI FILTERING

Personal Digital Assistant (PDA)

This unique product provides the user with the ability to keep track of life's little details; from dentist's appointments to stock quotes via the Internet. A PDA has the docking capability for one-touch data synchronization with your PC and access to email/Internet. Some PDA manufacturers even provide cellular phone, digital camera or MP3 module accessories.

With this stream-lined, high-tech functionality comes the threat of product damage due primarily to ESD (Electrostatic Discharge). ESD can be generated from various sources such as human contact or air discharge. In addition, PDAs, because of their higher operating frequencies, are more sensitive to EMI/RFI interference.

Recommended Devices

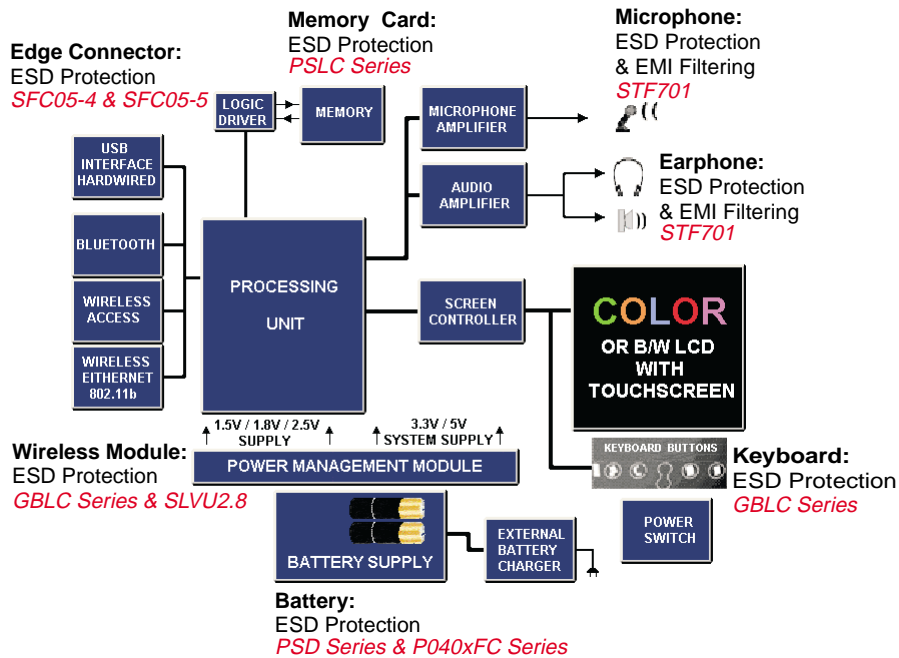

Transient Voltage Suppression (TVS) devices provide protection at board-level from the effects of Electrostatic Discharge (ESD) as defined by IEC 61000-4-2. When used with the proper shielding, these devices can provide additional EMI/RFI filtering.

APPLICATIONS

The following PDA circuits represent several applications for ESD and EMI protection.

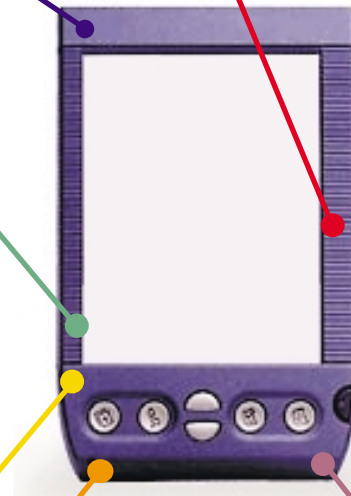
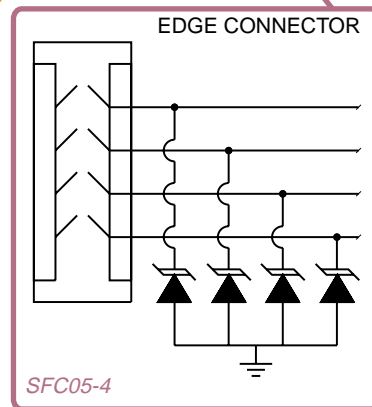
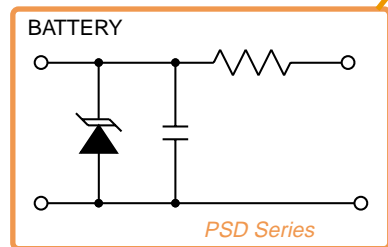
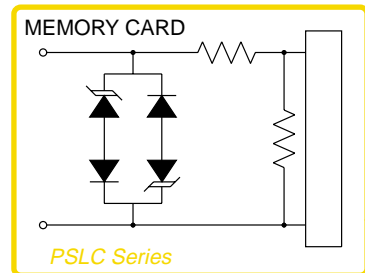
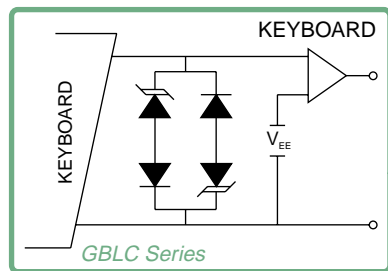
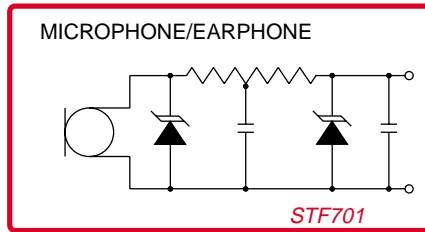
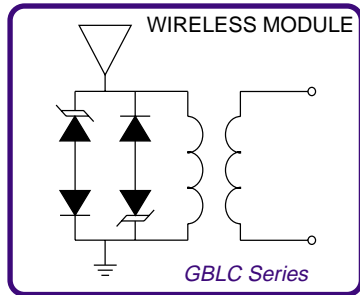

RECOMMENDED DEVICES



GBLC Series

- ❑ Capacitance: 3pF
- ❑ Low Clamping Voltage
- ❑ ESD > 40 kilovolts
- ❑ Unidirectional & Bidirectional Configurations
- ❑ 350 Watts Peak Pulse Power (8/20 μ s)
- ❑ SOD-323 Package



SLUV2.8

- ❑ Operating Voltage: 2.8
- ❑ Low Leakage Current: 0.1 μ A
- ❑ ESD > 40 kilovolts
- ❑ Capacitance: 5pF
- ❑ Unidirectional Configuration
- ❑ 400 Watts Peak Pulse Power (8/20 μ s)
- ❑ SOT-23 Package



STF701

- ❑ EMI/RFI Filtering/TVS
- ❑ Low Insertion Loss
- ❑ ESD > 25 kilovolts
- ❑ 175 Watts Peak Pulse Power (8/20 μ s)
- ❑ SC70-5L Package



PSD Series

- ❑ Replacement for MLV (0805)
- ❑ ESD > 40 kilovolts
- ❑ Unidirectional & Bidirectional Configurations
- ❑ Low Clamping Voltage
- ❑ 500 Watts Peak Pulse Power (8/20 μ s)
- ❑ SOD-323 Package



PSLC Series

- ❑ Low Capacitance: 10pF
- ❑ ESD > 40 kilovolts
- ❑ Unidirectional & Bidirectional Configurations
- ❑ 175 Watts Peak Pulse Power (8/20 μ s)
- ❑ SOT-143 Package



SFC05-4 & SFC05-5

- ❑ Chip Scale Packaging (0604)
- ❑ ESD > 25 kilovolts
- ❑ Protects Up to 5 Uni or 4 Bidirectional Lines
- ❑ 300 Watts Peak Pulse Power (8/20 μ s)



P040xFC Series

- ❑ Chip Scale Packaging (0402)
- ❑ ESD > 25 kilovolts
- ❑ Bidirectional Configurations
- ❑ Protects Up to 7 I/O Ports
- ❑ 250 Watts Peak Pulse Power (8/20 μ s)

DEVICE CHARACTERISTICS

PART NUMBER	RATED STAND-OFF VOLTAGE V_{WM} VOLTS	MINIMUM BREAKDOWN VOLTAGE @ 1 mA $V_{(BR)}$ VOLTS	MAXIMUM CLAMPING VOLTAGE @ 8/20 μ s V_C @ I_{SP}	MAXIMUM LEAKAGE CURRENT @ V_{WM} I_D μ A	MAXIMUM CAPACITANCE @ 0V, 1 Mhz C pF
GBLC03*	3.3	4.0	14.6V @ 24A	75	3
GBLC05*	5.0	6.0	17.5V @ 20A	5	3
GBLC08*	8.0	8.5	21.1V @ 16.6A	2	3
GBLC12*	12.0	13.3	28.0V @ 12.5A	1	3
GBLC15*	15.0	16.7	42.0V @ 8.3A	1	3
P0402FC3.3C**	3.3	4.0	12.5V @ 20.0A	125	150
P0402FC05C**	5.0	6.0	14.7V @ 17.0A	10	100
P0402FC08C**	8.0	8.5	19.2V @ 13.0A	10	75
P0402FC12C**	12.0	13.3	29.7V @ 9.0A	1	50
P0402FC15C**	15.0	16.7	35.7V @ 7.0A	1	40
P0402FC24C**	24.0	26.7	55.0V @ 5.0A	1	30
P0402FC36C**	36.0	40.0	84.0V @ 3.0A	1	25
PSLC03*	3.3	4.0	8.0V @ 20.0A	125	10
PSLC05*	5.0	6.0	14.0V @ 14.0A	20	10
PSLC08*	8.0	8.5	17.5V @ 10.0A	10	10
PSLC12*	12.0	13.3	26.0V @ 6.7A	1	10
PSLC15*	15.0	16.6	32.0V @ 5.3A	1	10
PSLC24*	24.0	26.7	55.0V @ 3.0A	1	10
PSD03*	3.3	4.0	12.0V @ 45.0A	125	800
PSD05*	5.0	6.0	14.5V @ 40.0A	10	550
PSD12*	12.0	13.3	30.0V @ 20.0A	1	185
PSD15*	15.0	16.7	34.0V @ 15.0A	1	150
PSD24*	24.0	26.7	44.0V @ 12.0A	1	88
SFC05-4	5.0	6.0	11.0V @ 24.0A	10	150
SFC05-5	5.0	6.0	11.0V @ 24.0A	10	150

*Bidirectional Configuration Offered. Add a "C" suffix when ordering, i.e., GBLC05C.

**Part number identification is as follows: P0404FCxxC for 0404 chip; P0406FCxxC for 0406 chip; P0408FCxxC for 0408 chip.

PART NUMBER	RATED STAND-OFF VOLTAGE V_{WM} VOLTS	MINIMUM BREAKDOWN VOLTAGE @ 1 mA $V_{(BR)}$ VOLTS	SERIES RESISTANCE EACH LINE R OHMS	REVERSE LEAKAGE CURRENT @ $V_{RWM} = 3.3V$ $T = 25^\circ C, I_D$ μ A	CAPACITOR EACH LINE $V_s = 0V$ $f = 1 MHz$ C pF
STF701	5	6.0	50	1.0	40

PART NUMBER	REVERSE STAND-OFF VOLTAGE (See Note 1) V_{WM} VOLTS	PUNCH THROUGH VOLTAGE (See Note 2) V_{PT} $I_{PT} = 2\mu A$ VOLTS	MAXIMUM CLAMPING VOLTAGE Pin 3 to 1 @ 8/20 μ s V_C @ I_{SP}	LEAKAGE CURRENT (See Note 3) @ $V_{WM} = 2.8V$ $T = 25^\circ C, I_D$ μ A	TYPICAL CAPACITANCE (See Note 4) @ 0V, 1 Mhz C pF
SLVU2.8	2.8	3.0	12.5V @ 24.0A	0.1	5.0

Note 1: From Pin 3 to 1 or Pin 2 to 1.

Note 2: From Pin 3 to 1.

Note 3: From Pin 3 to 1 or Pin 2 to 1.

Note 4: From Pin 2 to 1 (3 N.C.).



ProTek Devices, based in Tempe, Arizona USA, is a manufacturer of Transient Voltage Suppression (TVS) products designed specifically for the protection of electronic systems from the destructive effects of Lightning, Electrostatic Discharge (ESD), Nuclear Electromagnetic Pulse (NEMP) and Inductive Switching. With over 25 years of engineering and manufacturing experience, ProTek designs TVS devices that provide application specific protection solutions for voice, video and data related systems.

Contact ProTek for more information about other application specific brochures:

- ✓ *Computer Equipment/Systems*
- ✓ *Ethernet Equipment/Systems*
- ✓ *Modules*
- ✓ *Cellular Phones*
- ✓ *Telecom*
- ✓ *Set-Top Boxes*
- ✓ *xDSL*

ProTek Devices
2929 South Fair Lane
Tempe, Arizona 85282
USA
Tel: 602-431-8101
Fax: 602-431-2288
Email: sales@protek-tvs.com
Web: www.protekdevices.com